

EWP PRODUCT GUIDE

www.USPconnectors.com

For Use With Products Manufactured by



R O S E B U R G

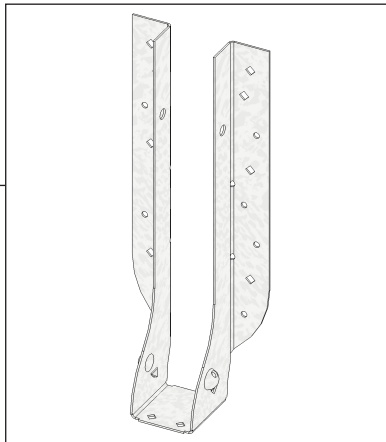

THF23140 ●

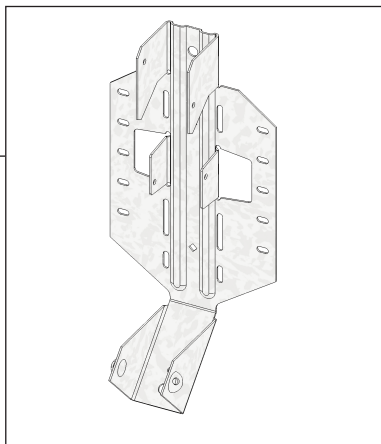

LSSH179 ●

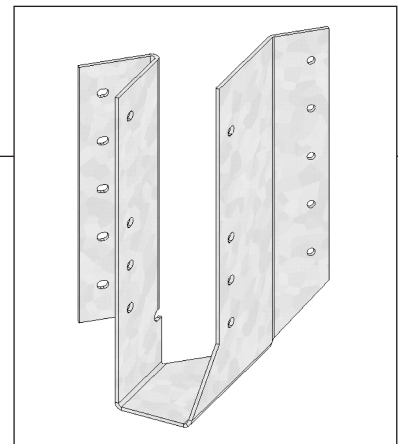

SKH1720L ●



A GIBALTAR INDUSTRIES COMPANY 

Lumberton • Largo • Montgomery • Houston • Rancho Cucamonga • Livermore • Thornhill, Ontario

2 GENERAL NOTES

Follow these instructions to ensure the proper installation of USP products.

- See current USP Full Line Catalog for General Notes, Warranty, and installation information for hanger models, joist sizes, and header situations not shown.
- Loads listed address hanger/header/fastener limitations assuming header material is Douglas Fir-Larch, Southern Pine, or LVL manufactured in the U.S. Joist reaction should be checked by a qualified designer to ensure proper hanger selection.
- Uplift loads have been increased 33% for wind or seismic loads and no further increase shall be permitted. Reduce loads according to code for normal duration loading such as cantilever construction.
- If hanger height is less than 60% of joist height, joist rotation may occur, therefore supplemental lateral restraints are required, see page 3.
- The type and quantity of fasteners used to install USP products is critical to connector performance. To achieve the allowable loads shown in this catalog, install with the fasteners specified for that particular product. All specified fasteners must be properly installed prior to applying

load of any kind to the connection.

- Throughout this catalog, dimensions are expressed in inches and loads in pounds, unless specifically noted otherwise.
- Load values for 10d and 16d designations in the fastener schedules throughout this catalog refer to common wire nails, unless noted otherwise.
- The allowable loads shown in this catalog are based on Allowable Stress Design methodology.
- *Multiple I-Joist Plies:* Fasten together multiple plies of wood I-Joists, in accordance with the manufacturer's installation guidelines, such that the joists act as a single unit.
- *Sloped I-Joists:* Use hangers with sloped seats and beveled web stiffeners whenever the slope exceeds the following: 1/2:12 for seat bearing lengths of 2 1/2" or less; 3/8:12 for bearing lengths between 2 1/2" and 3 1/2"; and 1/4:12 for bearing lengths in excess of 3 1/2".

Backer Blocks – Pattern the nails used to install backer blocks or web stiffeners in wood I-Joists to avoid splitting the block. The nail pattern should be sufficiently spaced to avoid the same grain line, particularly with solid sawn backer blocks. Backer blocks must be installed on wood I-Joists acting as the header, or supporting member. Install in accordance with the Roseburg Forest Products installation guidelines. The nails used

to install hangers mounted to an I-Joist header must penetrate through the web and into the backer block on the opposite side.

With top flange hangers, backer block required only for downward loads exceeding 250 lbs or for uplift conditions

Backer Block Installation:
Install tight to top flange (tight to bottom flange with face mount hangers). Attach with twelve 10d (3") nails, clinched when possible

Filler Block Installation:
Nail with ten 10d (3") nails, clinched. Use ten (3 1/2") nails from each side with RFP® Joists

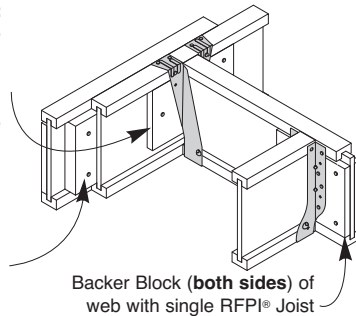

Filler and Backer Block sizes

Flange Width	Depth	Backer Block		Filler Block Size
		Thickness Required	Minimum ¹ Depth	
1-3/4"	9-1/2"	23/32"	5-1/2"	1-3/8" x 6" high
	11-7/8"			1-3/8" x 8" high
	14"			1-3/8" x 10" high
	16"			1-3/8" x 12" high
2-1/16"	9-1/2"	7/8"	7-1/4"	1-3/4" x 6" high
	11-7/8"			1-3/4" x 8" high
	14"			1-3/4" x 10" high
	16"			1-3/4" x 12" high
2-5/16"	9-1/2"	1"	7-1/4"	2" x 6" high
	11-7/8"			2" x 8" high
	14"			2" x 10" high
	16"			2" x 12" high
3-1/2"	11-7/8"	1-1/2"	7-1/4"	3" x 8" high
	14"			3" x 10" high
	16"			3" x 12" high

1) For face-mount hangers use net joist depth minus 3-1/4".

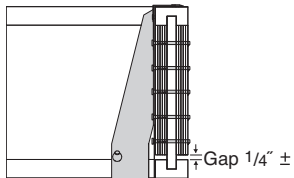

Typical THO backer block installation

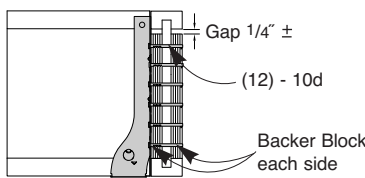

Typical THF backer block installation

Web Stiffener Attachment

Web Stiffeners may be required as noted below:

- Web stiffeners are always required in hangers that do not extend up to support the top flange of the RFP® Joist. Web stiffeners may be required with certain sloped or skewed hangers or to achieve uplift values. Refer to the Roseburg Forest Products installation requirements.

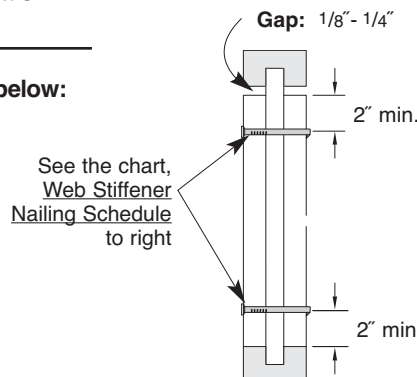

Web Stiffener Nailing Schedule

Joist Series	Joist Width	Joist Depth	Minimum Stiffener Size	Nails
RFP® 20	1-3/4"	9-1/2"	19/32" x 2-5/16"	(4) 8d
		11-7/8"		
		14"		
RFP® 400	2-1/16"	9-1/2"	3/4" x 2-5/16"	(4) 8d
		11-7/8"		
		14"		
RFP® 40	2-5/16"	9-1/2"	1" x 2-5/16"	(4) 8d
		11-7/8"		
		14"		
RFP® 50	1-3/4"	9-1/2"	19/32" x 2-5/16"	(4) 8d
		11-7/8"		
		14"		
RFP® 70	2-5/16"	9-1/2"	1" x 2-5/16"	(4) 8d
		11-7/8"		
		14"		
RFP® 90	3-1/2"	11-7/8"	1-1/2" x 2-5/16"	(4) 10d
		14"		
		16"		

Support Height & Lateral Stability

Hangers for joists **without web stiffeners** must support the I-Joist's top flange and provide lateral resistance with no more than 1/8" horizontal deflection.

Hangers for joists **with web stiffeners** must support a minimum of 60% of joist depth.



(Top flange support requirements can be verified in *EWP Top Mount Hangers* charts under the *Web Stiffener Req.* column of USP's *Full Line Catalog*.)

Nailer Installations

Correct Hanger Attachment to Nailers

A nailer or sill plate is considered to be any wood member attached to a steel beam, concrete block wall, concrete stem wall, or other type of support which is unsuitable for nailing, and is used as a nailing surface for top mount hangers to hold beams or joists.

Nailer Sized Correctly

Top flange of hanger is fully supported and recommended nails have full penetration into nailer, resulting in a carried member hanging safely at the proper height.

The nailer must be sized to fit the support width as shown and be of sufficient thickness to satisfy recommended top flange nailing requirements. A design professional must specify nailer attachment to steel beams.

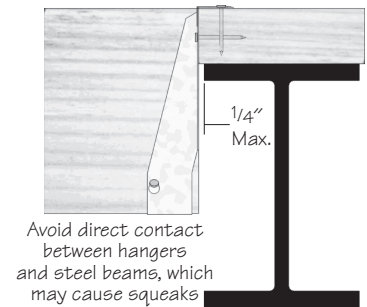

Wrong Nailer Size Causes Component Failure



⚠ Too Narrow

Top flange not fully supported can cause nail breakout. Or, by fully supporting top flange, hanger is tilted back, causing lifting of carried member which results in uneven surfaces and squeaky floors.

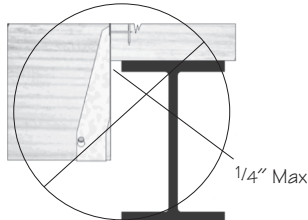

⚠ Too Wide

Loading can cause cross grain breaking of nailer. The recommended nailer overhang is 1/4" maximum per side.

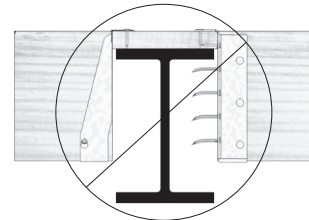

⚠ Too Thin

Top flange nailing cannot fully penetrate nailer, causing reduced allowable loads. Never use hangers which require multiple face nails with a nailer or sill plate since the allowable loads are dependent on all nail holes being used.

Top Flange Hangers

The thickness of the hanger metal and nail heads on top mount hangers must be evaluated for the effect on subsequent sheathing. Ensure the top mount hanger is installed so the flanges of the hanger are not *over-spread* which tends to elevate the supported I-Joist, causing uneven floor surfaces and squeaking. Similarly, ensure the hanger is installed plumb such that the face flanges of the hanger are mounted firmly against the wide-face surface of the header.

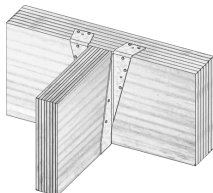

Flush framing

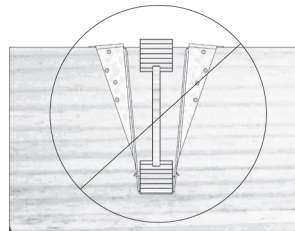

⚠ Hanger over-spread

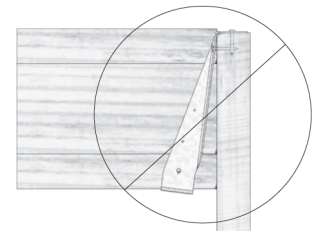

⚠ Hanger not plumb

4 SINGLE RFPI®-JOISTS

Joist Height	Top Mount Hangers ^{4,6}						Face Mount Hangers					
	USP Stock No. ¹	Fastener Schedule ⁵		Uplift ²		Down Load ²	USP Stock No. ¹	Fastener Schedule ⁵		Uplift ²		Down Load ²
		Header	Joist	133%	160%			Header	Joist	133%	160%	
RFPI® 20												
Joist Width = 1-3/4"												
9-1/2	THO17950	(6) 10d	(2) 10d x 1-1/2	270	270	1260	THF17925 Min	(8) 10d	(2) 10d x 1-1/2	280	280	910
							THF17925 Max	(12) 10d				1370
11-7/8	THO17118	(6) 10d	(2) 10d x 1-1/2	270	270	1305	THF17112 Min	(8) 10d	(2) 10d x 1-1/2	280	280	910
							THF17112 Max	(16) 10d				1825
14	THO17140	(10) 10d	(2) 10d x 1-1/2	230	230	1760	THF17140 Min	(12) 10d	(2) 10d x 1-1/2	280	280	1370
							THF17140 Max	(20) 10d				2280
RFPI® 400												
Joist Width = 2-1/16"												
9-1/2	TFL2095	(6) 10d	(2) 10d x 1-1/2	300	360	1245	THF20925 Min	(8) 10d	(2) 10d x 1-1/2	280	280	910
							THF20925 Max	(12) 10d				1370
11-7/8	TFL20118	(6) 10d	(2) 10d x 1-1/2	300	360	1245	THF20112 Min	(8) 10d	(2) 10d x 1-1/2	280	280	910
							THF20112 Max	(16) 10d				1825
14	TFL2014	(6) 10d	(2) 10d x 1-1/2	300	360	1245	THF20140 Min	(12) 10d	(2) 10d x 1-1/2	280	280	1370
							THF20140 Max	(20) 10d				2280
16	TFL2016	(6) 10d	(2) 10d x 1-1/2	300	360	1245	THF20157	(24) 10d	(2) 10d x 1-1/2	280	280	2735
RFPI® 40												
Joist Width = 2-5/16"												
9-1/2	TFL2395	(6) 10d	(2) 10d x 1-1/2	300	360	1245	THF23925	(12) 10d	(2) 10d x 1-1/2	175	175	1370
11-7/8	TFL23118	(6) 10d	(2) 10d x 1-1/2	300	360	1245	THF23118	(14) 10d	(2) 10d x 1-1/2	300	360	1595
14	TFL2314	(6) 10d	(2) 10d x 1-1/2	300	360	1245	THF23140	(18) 10d	(2) 10d x 1-1/2	300	360	2090
16	TFL2316	(6) 10d	(2) 10d x 1-1/2	300	360	1245	THF23160	(22) 10d	(2) 10d x 1-1/2	300	360	2550
RFPI® 50												
Joist Width = 1-3/4"												
9-1/2	THO17950	(6) 10d	(2) 10d x 1-1/2	270	270	1260	THF17925 Min	(8) 10d	(2) 10d x 1-1/2	280	280	910
							THF17925 Max	(12) 10d				1370
11-7/8	THO17118	(6) 10d	(2) 10d x 1-1/2	270	270	1305	THF17112 Min	(8) 10d	(2) 10d x 1-1/2	280	280	910
							THF17112 Max	(16) 10d				1825
14	THO17140	(10) 10d	(2) 10d x 1-1/2	230	230	1760	THF17140 Min	(12) 10d	(2) 10d x 1-1/2	280	280	1370
							THF17140 Max	(20) 10d				2280
16	THO17160	(10) 10d	(2) 10d x 1-1/2	230	230	1760	THF17157	(24) 10d	(2) 10d x 1-1/2	280	280	2735
RFPI® 70												
Joist Width = 2-5/16"												
9-1/2	TFL2395	(6) 10d	(2) 10d x 1-1/2	300	360	1245	THF23925	(12) 10d	(2) 10d x 1-1/2	175	175	1370
11-7/8	TFL23118	(6) 10d	(2) 10d x 1-1/2	300	360	1245	THF23118	(14) 10d	(2) 10d x 1-1/2	300	360	1595
14	TFL2314	(6) 10d	(2) 10d x 1-1/2	300	360	1245	THF23140	(18) 10d	(2) 10d x 1-1/2	300	360	2090
16	TFL2316	(6) 10d	(2) 10d x 1-1/2	300	360	1245	THF23160	(22) 10d	(2) 10d x 1-1/2	300	360	2550
RFPI® 90												
Joist Width = 3-1/2"												
11-7/8	THO35118	(10) 10d	(2) 10d x 1-1/2	300	360	2050	THF35112	(16) 10d	(2) 10d x 1-1/2	245	245	1825
14	THO35140	(12) 10d	(2) 10d x 1-1/2	300	360	2715	THF35140	(20) 10d	(2) 10d x 1-1/2	245	245	2320
16	THO35160	(12) 10d	(2) 10d x 1-1/2	300	360	2715	THF35157	(22) 10d	(2) 10d x 1-1/2	245	245	2550

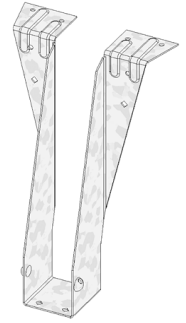

THO

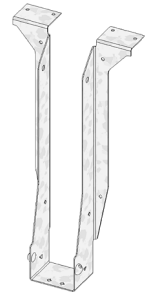

TFL

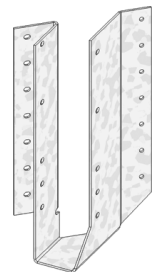

SKH_L
left shown

- 1) Web stiffeners may be required for hangers by Roseburg Forest Products. See notes on page 2.
- 2) Loads listed are based on hanger attachment to a DF-L or SYP species solid sawn or glulam beam, or RIGIDLAM® LVL header. Some loads may be increased for duration of load adjustments. Refer to USP Full Line Catalog for details.
- 3) Uplift loads have been increased 33% or 60% for wind and seismic loading; no further increase shall be permitted.
- 4) Top Mount Hangers require minimum 3" header thickness for THO series hangers; 3-1/2" minimum header thickness for all other stock numbers.
- 5) 10d x 1-1/2" nails are 9 gauge (0.148" diameter) by 1-1/2" long. Minimum nail penetration shall be 1-1/2" for 10d nails. 16d sinkers (0.148" diameter) by 3-1/4" long may be substituted for 10d common nails with no load reduction.
- 6) For top mount hangers supported by I-Joist headers with a flange thickness less than 1/2", consult USP and Roseburg Forest Products for hanger limitations.

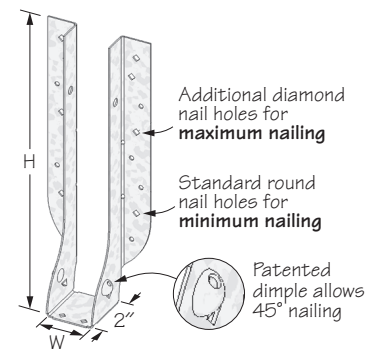

THF single

Joist Height	Adjustable Height Hangers						Field Sloped and Skewed Hangers					Skewed 45° Hangers						
	USP Stock No. ^{1,6}	Fastener Schedule ⁴		Uplift ³		Down Load ²	USP Stock No. ^{1,7}	Fastener Schedule ⁴		Uplift ³		Down Load ²	USP Stock No. ^{1,7}	Fastener Schedule ⁴		Uplift ³		Down Load ²
		Header	Joist	133%	160%			Header	Joist	133%	160%			Header	Joist	133%	160%	
RFPI® 20																		
Joist Width = 1-3/4"																		
9-1/2	---	---	---	---	---	---	LSSH179	(10) 10d	(7) 10d x 1-1/2	1065	1065	1140	SKH1720L/R	(14) 10d	(10) 10d x 1-1/2	1505	1565	1625
11-7/8	MSH1718	(6) 10d	(4) 10d x 1-1/2	---	---	2165	LSSH179	(10) 10d	(7) 10d x 1-1/2	1065	1065	1140	SKH1724L/R	(16) 10d	(10) 10d x 1-1/2	1505	1565	1855
14	MSH1722	(6) 10d	(4) 10d x 1-1/2	---	---	2165	LSSH179	(10) 10d	(7) 10d x 1-1/2	1065	1065	1140	SKH1724L/R	(16) 10d	(10) 10d x 1-1/2	1505	1565	1855
RFPI® 400																		
Joist Width = 2-1/16"																		
9-1/2	---	---	---	---	---	---	LSSH20	(10) 10d	(7) 10d x 1-1/2	980	980	1140	SKH2020L/R	(14) 10d	(10) 10d x 1-1/2	1505	1565	1625
11-7/8	---	---	---	---	---	---	LSSH20	(10) 10d	(7) 10d x 1-1/2	980	980	1140	SKH2020L/R	(14) 10d	(10) 10d x 1-1/2	1505	1565	1625
14	---	---	---	---	---	---	LSSH20	(10) 10d	(7) 10d x 1-1/2	980	980	1140	SKH2024L/R	(16) 10d	(10) 10d x 1-1/2	1505	1565	1855
16	---	---	---	---	---	---	LSSH20 ⁸	(10) 10d	(7) 10d x 1-1/2	980	980	1140	SKH2024L/R	(16) 10d	(10) 10d x 1-1/2	1505	1565	1855
RFPI® 40																		
Joist Width = 2-5/16"																		
9-1/2	---	---	---	---	---	---	LSSH23	(10) 10d	(7) 10d x 1-1/2	980	980	1140	SKH2320L/R	(14) 10d	(10) 10d x 1-1/2	1505	1565	1625
11-7/8	MSH2318	(6) 10d	(4) 10d x 1-1/2	---	---	2165	LSSH23	(10) 10d	(7) 10d x 1-1/2	980	980	1140	SKH2320L/R	(14) 10d	(10) 10d x 1-1/2	1505	1565	1625
14	MSH2318	(6) 10d	(4) 10d x 1-1/2	---	---	2165	LSSH23	(10) 10d	(7) 10d x 1-1/2	980	980	1140	SKH2324L/R	(16) 10d	(10) 10d x 1-1/2	1505	1565	1855
16	MSH2322	(6) 10d	(4) 10d x 1-1/2	---	---	2165	LSSH23 ⁸	(10) 10d	(7) 10d x 1-1/2	980	980	1140	SKH2324L/R	(16) 10d	(10) 10d x 1-1/2	1505	1565	1855
RFPI® 50																		
Joist Width = 1-3/4"																		
9-1/2	---	---	---	---	---	---	LSSH179	(10) 10d	(7) 10d x 1-1/2	1065	1065	1140	SKH1720L/R	(14) 10d	(10) 10d x 1-1/2	1505	1565	1625
11-7/8	MSH1718	(6) 10d	(4) 10d x 1-1/2	---	---	2165	LSSH179	(10) 10d	(7) 10d x 1-1/2	1065	1065	1140	SKH1724L/R	(16) 10d	(10) 10d x 1-1/2	1505	1565	1855
14	MSH1722	(6) 10d	(4) 10d x 1-1/2	---	---	2165	LSSH179	(10) 10d	(7) 10d x 1-1/2	1065	1065	1140	SKH1724L/R	(16) 10d	(10) 10d x 1-1/2	1505	1565	1855
16	MSH1722	(6) 10d	(4) 10d x 1-1/2	---	---	2165	LSSH179 ⁸	(10) 10d	(7) 10d x 1-1/2	1065	1065	1140	SKH1724L/R	(16) 10d	(10) 10d x 1-1/2	1505	1565	1855
RFPI® 70																		
Joist Width = 2-5/16"																		
9-1/2	---	---	---	---	---	---	LSSH23	(10) 10d	(7) 10d x 1-1/2	980	980	1140	SKH2320L/R	(14) 10d	(10) 10d x 1-1/2	1505	1565	1625
11-7/8	MSH2318	(6) 10d	(4) 10d x 1-1/2	---	---	2165	LSSH23	(10) 10d	(7) 10d x 1-1/2	980	980	1140	SKH2320L/R	(14) 10d	(10) 10d x 1-1/2	1505	1565	1625
14	MSH2318	(6) 10d	(4) 10d x 1-1/2	---	---	2165	LSSH23	(10) 10d	(7) 10d x 1-1/2	980	980	1140	SKH2324L/R	(16) 10d	(10) 10d x 1-1/2	1505	1565	1855
16	MSH2322	(6) 10d	(4) 10d x 1-1/2	---	---	2165	LSSH23 ⁸	(10) 10d	(7) 10d x 1-1/2	980	980	1140	SKH2324L/R	(16) 10d	(10) 10d x 1-1/2	1505	1565	1855
RFPI® 90																		
Joist Width = 3-1/2"																		
11-7/8	MSH422	(6) 10d	(6) 10d	---	---	2025	LSSH35	(14) 16d	(12) 10d x 1-1/2	1585	1585	1920	SKH410L/R ⁵	(16) 16d	(10) 16d	1565	1565	2240
14	---	---	---	---	---	---	LSSH35	(14) 16d	(12) 10d x 1-1/2	1585	1585	1920	SKH414L/R ⁵	(22) 16d	(10) 16d	1565	1565	3080
16	---	---	---	---	---	---	LSSH35 ⁸	(14) 16d	(12) 10d x 1-1/2	1585	1585	1920	SKH414L/R ⁵	(22) 16d	(10) 16d	1565	1565	3080

- 1) Shaded hangers require web stiffeners at joist ends.
- 2) Loads listed are based on hanger attachment to a DF-L or SYP species solid sawn or glulam beam, RFPI®-Joists, or RIGIDLAM® LVL header. Some loads may be increased for duration of load adjustments. Refer to USP Full Line Catalog for details.
- 3) Uplift loads have been increased 33% or 60% for wind and seismic loading; no further increase shall be permitted.
- 4) 10d x 1-1/2" nails are 9 gauge (0.148" diameter) by 1-1/2" long. Minimum nail penetration shall be 1-1/2" for 10d nails and 1-5/8" for 16d nails.
- 5) Miter cut required on end of joist to achieve design loads.
- 6) For additional sizes, stock numbers, and modifications not shown, refer to USP's Full Line Catalog.
- 7) Hangers utilizing 16d nails are not compatible with I-joist headers.
- 8) Supplemental lateral support connection recommended when hanger height is less than 60% of joist height.

LSSH Installation:

- Use all specified fasteners.

Steps:

1. Position LSSH connector against plumb-cut end of joist. Fasten joist side flanges on both sides with 10d x 1-1/2" nails. Bend seat up to fit against joist bottom and drive (1) 10d x 1-1/2" nail through bottom seat into joist bottom flange. Drive (2) 10d x 1-1/2" nails at downward angle through dimpled nailing guides.
 2. Lean connector and rafter end against ridge beam at desired position. Install 10d or 16d nails through nail holes into ridge beam at right 90° angle. If skewing the rafter, only drive nails into ridge beam on inside flange.
 3. Bend flange to desired angle.
 4. Hammer outside flange until edge touches header. Fasten outside flange to ridge by driving 10d or 16d nails through nail holes.
- Web stiffeners are required for all wood I-Joist installations.
 - Designer may consider adding a tension restraint for the supported member for roof slopes exceeding 6/12.

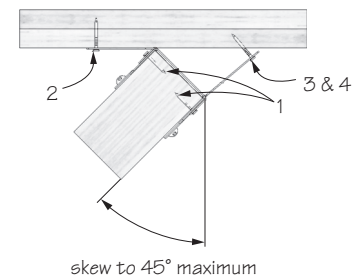
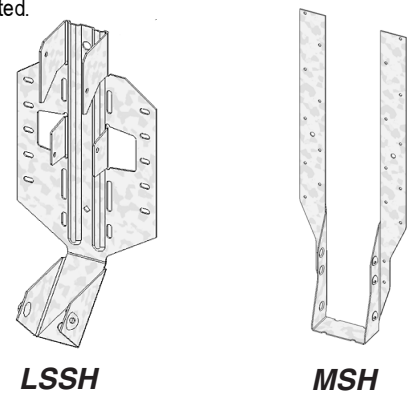

6 DOUBLE RFPI®-JOISTS

Joist Height	Top Mount Hangers ^{4,10}						Face Mount Hangers					Skewed 45° Hangers						
	USP Stock No. ^{1,9}	Fastener Schedule ⁵		Uplift ³		Down Load ²	USP Stock No. ^{1,6,9}	Fastener Schedule ⁵		Uplift ³		Down Load ²	USP Stock No. ^{1,9}	Fastener Schedule ⁵		Uplift ³		Down Load ²
		Header	Joist	133%	160%			Header	Joist	133%	160%			Header	Joist	133%	160%	
Double RFPI® 20																		
Joist Width = 3-1/2"																		
9-1/2	THO35950	(10) 10d	(2) 10d x 1-1/2	300	360	2050	THF35925	(12) 10d	(2) 10d x 1-1/2	245	245	1370	SKH410L/R ⁷	(16) 16d	(10) 16d	1565	1565	2240
11-7/8	THO35118	(10) 10d	(2) 10d x 1-1/2	300	360	2050	THF35112	(16) 10d	(2) 10d x 1-1/2	245	245	1825	SKH410L/R ⁷	(16) 16d	(10) 16d	1565	1565	2240
14	THO35140	(12) 10d	(2) 10d x 1-1/2	300	360	2715	THF35142	(20) 10d	(2) 10d x 1-1/2	245	245	2320	SKH414L/R ⁷	(22) 16d	(10) 16d	1565	1565	3080
Double RFPI® 400																		
Joist Width = 4-1/8"																		
9-1/2	THO20950-2	(10) 16d	(6) 10d	930	1115	2330	THF20925-2	(12) 10d	(6) 10d	930	1115	1390	SKH2020L/R-2	(14) 10d	(10) 10d	1575	1890	1650
11-7/8	THO20118-2	(10) 16d	(6) 10d	930	1115	2330	THF20112-2	(16) 10d	(6) 10d	930	1115	1855	SKH2020L/R-2	(14) 10d	(10) 10d	1575	1890	1650
14	THO20140-2	(10) 16d	(6) 10d	1015	1175	2330	THF20140-2	(20) 10d	(6) 10d	930	1115	2320	SKH2024L/R-2	(16) 10d	(10) 10d	1575	1890	1890
16	THO20160-2	(10) 16d	(6) 10d	1015	1175	2330	---	---	---	---	---	---	SKH2024L/R-2	(16) 10d	(10) 10d	1575	1890	1890
Double RFPI® 40																		
Joist Width = 4-5/8"																		
9-1/2	THO23950-2	(10) 16d	(6) 10d	1015	1175	2630	THF23925-2	(14) 10d	(6) 10d	930	1115	1625	SKH2320L/R-2	(14) 10d	(10) 10d	1575	1890	1650
11-7/8	THO23118-2	(10) 16d	(6) 10d	1015	1175	2630	THF23118-2	(16) 10d	(6) 10d	930	1115	1855	SKH2320L/R-2	(14) 10d	(10) 10d	1575	1890	1650
14	THO23140-2	(12) 16d	(6) 10d	1015	1175	2630	THF23140-2	(20) 10d	(6) 10d	1000	1200	2500	SKH2324L/R-2	(16) 10d	(10) 10d	1575	1890	1890
16	THO23160-2	(12) 16d	(6) 10d	1015	1175	2630	THF23160-2	(24) 10d	(6) 10d	1000	1200	3000	SKH2324L/R-2	(16) 10d	(10) 10d	1575	1890	1890
Double RFPI® 50																		
Joist Width = 3-1/2"																		
9-1/2	THO35950	(10) 10d	(2) 10d x 1-1/2	300	360	2050	THF35925	(12) 10d	(2) 10d x 1-1/2	245	245	1370	SKH410L/R ⁷	(16) 16d	(10) 16d	1565	1565	2240
11-7/8	THO35118	(10) 10d	(2) 10d x 1-1/2	300	360	2050	THF35112	(16) 10d	(2) 10d x 1-1/2	245	245	1825	SKH410L/R ⁷	(16) 16d	(10) 16d	1565	1565	2240
14	THO35140	(12) 10d	(2) 10d x 1-1/2	300	360	2715	THF35140	(20) 10d	(2) 10d x 1-1/2	245	245	2320	SKH414L/R ⁷	(22) 16d	(10) 16d	1565	1565	3080
16	THO35160	(12) 10d	(2) 10d x 1-1/2	300	360	2715	THF35157	(22) 10d	(2) 10d x 1-1/2	245	245	2550	SKH414L/R ⁷	(22) 16d	(10) 16d	1565	1565	3080
Double RFPI® 70																		
Joist Width = 4-5/8"																		
9-1/2	THO23950-2	(10) 16d	(6) 10d	1015	1175	2630	THF23925-2	(14) 10d	(6) 10d	930	1115	1625	SKH2320L/R-2	(14) 10d	(10) 10d	1575	1890	1650
11-7/8	THO23118-2	(10) 16d	(6) 10d	1015	1175	2630	THF23118-2	(16) 10d	(6) 10d	930	1115	1855	SKH2320L/R-2	(14) 10d	(10) 10d	1575	1890	1650
14	THO23140-2	(12) 16d	(6) 10d	1015	1175	2630	THF23140-2	(20) 10d	(6) 10d	1000	1200	2500	SKH2324L/R-2	(16) 10d	(10) 10d	1575	1890	1890
16	THO23160-2	(12) 16d	(6) 10d	1015	1175	2630	THF23160-2	(24) 10d	(6) 10d	1000	1200	3000	SKH2324L/R-2	(16) 10d	(10) 10d	1575	1890	1890
Double RFPI® 90																		
Joist Width = 7"																		
11-7/8	BPH71118	(10) 16d	(6) 10d	1000	1200	3510	HD7120	(16) 16d	(6) 10d	945	1130	2240	HD7120-SK45L/R ^{7,8}	(16) 16d	(6) 10d	710	850	2240
14	BPH7114	(10) 16d	(6) 10d	1000	1200	3510	HD7140	(20) 16d	(8) 10d	1260	1510	2800	HD7140-SK45L/R ^{7,8}	(20) 16d	(8) 10d	945	1135	2800
16	BPH7116	(10) 16d	(6) 10d	1000	1200	3510	HD7160	(24) 16d	(8) 10d	1260	1510	3360	HD7160-SK45L/R ^{7,8}	(24) 16d	(8) 10d	945	1135	3360

- 1) Shaded hangers require web stiffeners at joist ends. Web stiffeners may be required for non-shaded hangers by Roseburg Forest Products. See notes on page 2.
- 2) Loads listed are based on hanger attachment to a DF-L or SYP species solid sawn or glulam beam, or RIGIDLAM® LVL header.
Some loads may be increased for duration of load adjustments. Refer to USP Full Line Catalog for details.
- 3) Uplift loads have been increased 33% or 60% for wind and seismic loading; no further increase shall be permitted.
- 4) Top Mount Hangers require minimum 3" header thickness for THO series hangers; 3-1/2" minimum header thickness for all other stock numbers.
- 5) 10d x 1-1/2" nails are 9 gauge (0.148" diameter) by 1-1/2" long.
Minimum nail penetration shall be 1-1/2" for 10d nails and 1-5/8" for 16d nails.
16d sinkers (0.148" diameter) by 3-1/4" long may be substituted for 10d common nails with no load reduction.
- 6) For additional sizes, stock numbers, and modifications not shown, refer to USP's Full Line Catalog.
- 7) Miter cut required on end of joist to achieve design loads.
- 8) Hangers are special order. Consult USP for pricing and lead times.
- 9) Hangers utilizing 16d nails are not compatible with I-joist headers.
- 10) For top mount hangers supported by I-joist headers with a flange thickness less than 1/2", consult USP and Roseburg Forest Products for hanger limitations.

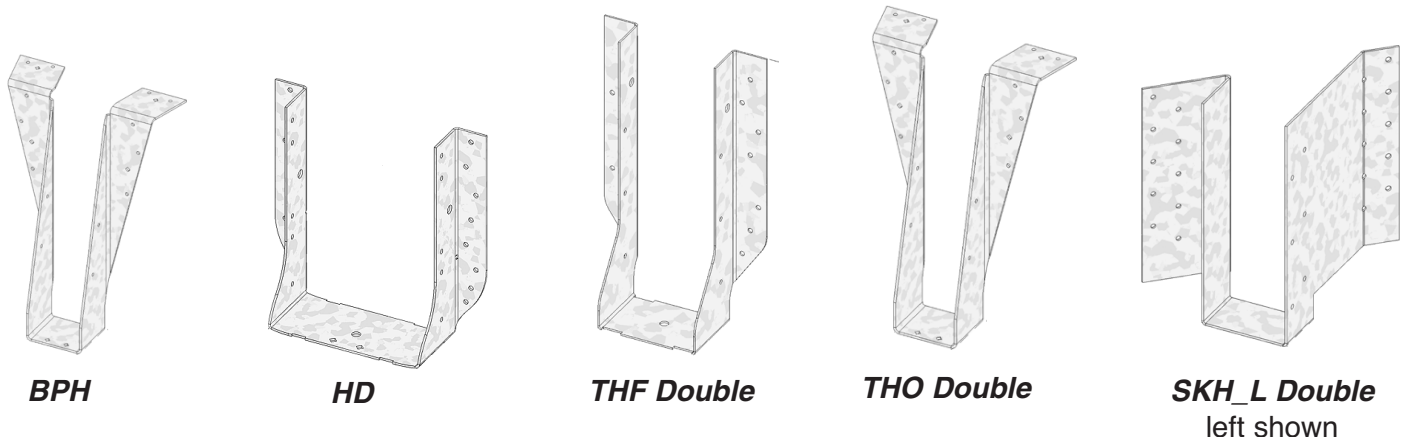

Joist Height	Adjustable Height Hangers						Field Sloped and Skewed Hangers					
	USP Stock No. ^{1,5,6}	Fastener Schedule ⁴		Uplift ³		Down Load ²	USP Stock No. ^{1,5,6}	Fastener Schedule ⁴		Uplift ³		Down Load ²
		Header	Joist	133%	160%			Header	Joist	133%	160%	
Double RFPI® 20 Joist Width = 3-1/2"												
9-1/2	MSH422	(6) 10d	(6) 10d	--	--	2025	LSSH35	(14) 16d	(12) 10d x 1-1/2	1585	1585	1920
11-7/8	MSH422	(6) 10d	(6) 10d	--	--	2025	LSSH35	(14) 16d	(12) 10d x 1-1/2	1585	1585	1920
14	--	--	--	--	--	--	LSSH35	(14) 16d	(12) 10d x 1-1/2	1585	1585	1920
Double RFPI® 400 Joist Width = 4-1/8"												
9-1/2	See USP Full Line Catalog for specialty hanger options						See USP Full Line Catalog for specialty hanger options					
11-7/8												
14												
16												
Double RFPI® 40 Joist Width = 4-5/8"												
9-1/2	MSH2322-2	(6) 10d	(4) 10d	--	--	2210	See USP Full Line Catalog for specialty hanger options					
11-7/8	MSH2322-2	(6) 10d	(4) 10d	--	--	2210						
14	MSH2322-2	(6) 10d	(4) 10d	--	--	2210						
16	--	--	--	--	--	--						
Double RFPI® 50 Joist Width = 3-1/2"												
9-1/2	MSH422	(6) 10d	(6) 10d	--	--	2025	LSSH35	(14) 16d	(12) 10d x 1-1/2	1585	1585	1920
11-7/8	MSH422	(6) 10d	(6) 10d	--	--	2025	LSSH35	(14) 16d	(12) 10d x 1-1/2	1585	1585	1920
14	See USP Full Line Catalog for specialty hanger options						LSSH35	(14) 16d	(12) 10d x 1-1/2	1585	1585	1920
16							LSSH35 ⁷	(14) 16d	(12) 10d x 1-1/2	1585	1585	1920
Double RFPI® 70 Joist Width = 4-5/8"												
9-1/2	MSH2322-2	(6) 10d	(4) 10d	--	--	2210	See USP Full Line Catalog for specialty hanger options					
11-7/8	MSH2322-2	(6) 10d	(4) 10d	--	--	2210						
14	MSH2322-2	(6) 10d	(4) 10d	--	--	2210						
16	--	--	--	--	--	--						
Double RFPI® 90 Joist Width = 7"												
11-7/8	--	--	--	--	--	--	See USP Full Line Catalog for specialty hanger options					
14	MSH422-2	(8) 16d	(6) 16d	--	--	4200						
16	MSH422-2	(8) 16d	(6) 16d	--	--	4200						

- 1) Shaded hangers require web stiffeners at joist ends.
- 2) Loads listed are based on hanger attachment to a DF-L or SYP species solid sawn or glulam beam, RFPI®-Joists, or RIGIDLAM® LVL header. Some loads may be increased for duration of load adjustments. Refer to USP Full Line Catalog for details.
- 3) Uplift loads have been increased 33% or 60% for wind and seismic loading; no further increase shall be permitted.
- 4) 10d x 1-1/2" nails are 9 gauge (0.148" diameter) by 1-1/2" long.
Minimum nail penetration shall be 1-1/2" for 10d nails and 1-5/8" for 16d nails.
16d sinkers (0.148" diameter) by 3-1/4" long may be substituted for 10d common nails with no load reduction.
- 5) For additional sizes, stock numbers, and modifications not shown, refer to USP's Full Line Catalog.
- 6) Hangers utilizing 16d nails are not compatible with I-joist headers.
- 7) Supplemental lateral support connection recommended when hanger height is less than 60% of joist height.

LSSH Installation:

- Use all specified fasteners.

Steps:

1. Position LSSH connector against plumb-cut end of joist. Fasten joist side flanges on both sides with 10d x 1-1/2" nails. Bend seat up to fit against joist bottom and drive (1) 10d x 1-1/2" nail through bottom seat into joist bottom flange. Drive (2) 10d x 1-1/2" nails at downward angle through dimpled nailing guides.
2. Lean connector and rafter end against ridge beam at desired position. Install 10d or 16d nails through nail holes into ridge beam at right 90° angle. If skewing the rafter, only drive nails into ridge beam on inside flange.
3. Bend flange to desired angle.
4. Hammer outside flange until edge touches header. Fasten outside flange to ridge by driving 10d or 16d nails through nail holes.

- Web stiffeners are required for all wood I-Joist installations.
- Designer may consider adding a tension restraint for the supported member for roof slopes exceeding 6/12.

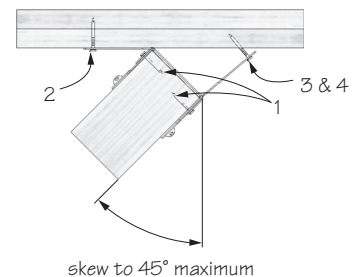
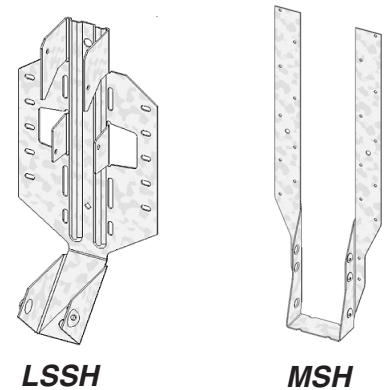

8 RIGIDLAM® LVL BEAMS & HEADERS

Joist Height	USP Stock No. ⁶	Top Mount Hangers ³					Face Mount Hangers									
		Fastener Schedule ⁴		Uplift ²		Down Load ¹	USP Stock No. ⁶	Fastener Schedule ⁴		Uplift ²		Down Load ¹				
		Header	Joist	133%	160%			Header	Joist	133%	160%	100%	115%	125%		
1-3/4" RIGIDLAM® LVL													Header Width = 1-3/4"			
9-1/2	THO17950	(6) 10d	(2) 10d x 1-1/2	270	270	1345	HD17925	(18) 16d	(6) 10d x 1-1/2	910	1065	2520	2775	2775		
	PHXU1795	(8) 16d	(6) 10d x 1-1/2	970	970	4425	HUS179 ⁵	(30) 16d	(10) 16d	3205	3205	4925	5130	5270		
11-7/8	THO17118	(6) 10d	(2) 10d x 1-1/2	270	270	1345	HD17112	(22) 16d	(6) 10d x 1-1/2	910	1065	2870	2975	3045		
	PHXU17118	(8) 16d	(6) 10d x 1-1/2	970	970	4425	HUS179 ⁵	(30) 16d	(10) 16d	3205	3205	4925	5130	5270		
14	THO17140	(10) 10d	(2) 10d x 1-1/2	230	230	1760	HD1714	(26) 16d	(8) 10d x 1-1/2	1065	1065	3100	3235	3330		
	PHXU1714	(8) 16d	(6) 10d x 1-1/2	970	970	4425	HUS179 ⁵	(30) 16d	(10) 16d	3205	3205	4925	5130	5270		
2 Ply 1-3/4" RIGIDLAM® LVL													Header Width = 3-1/4"			
9-1/2	PHXU3595	(8) 16d	(6) 10d	1035	1240	6650	THD410	(38) 16d	(20) 10d	3145	3775	5320	6120	6650		
	HLBH3595	(15) NA16D-RS	(6) 16d	1420	1420	10620	THDH410 ⁵	(46) 16d	(12) 16d	3490	3490	8170	8260	8260		
11-7/8	PHXU35118	(8) 16d	(6) 10d	1035	1240	6650	THD410	(38) 16d	(20) 10d	3145	3775	5320	6120	6650		
	HLBH35118	(15) NA16D-RS	(6) 16d	1420	1420	10620	THDH412 ⁵	(56) 16d	(14) 16d	4935	5925	9875	11115	11325		
14	PHXU3514	(8) 16d	(6) 10d	1035	1240	6650	THD410	(38) 16d	(20) 10d	3145	3775	5320	6120	6650		
	HLBH3514	(15) NA16D-RS	(6) 16d	1420	1420	10620	THDH414 ⁵	(66) 16d	(16) 16d	5645	6770	11100	11455	11690		
16	PHXU3516	(8) 16d	(6) 10d	1035	1240	6650	THD412	(48) 16d	(20) 10d	3145	3775	6650	6650	6650		
	HLBH3516	(15) NA16D-RS	(6) 16d	1420	1420	10620	THDH414 ⁵	(66) 16d	(16) 16d	5645	6770	11100	11455	11690		
18	PHXU3518	(8) 16d	(6) 10d	1035	1240	6650	THD412	(48) 16d	(20) 10d	3145	3775	6650	6650	6650		
	HLBH3518	(15) NA16D-RS	(6) 16d	1420	1420	10620	THDH414 ⁵	(66) 16d	(16) 16d	5645	6770	11100	11455	11690		

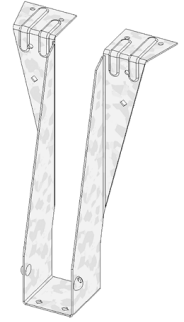

THO

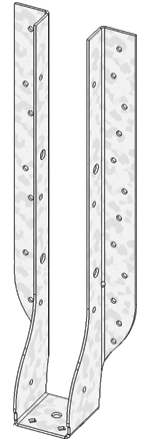

HD

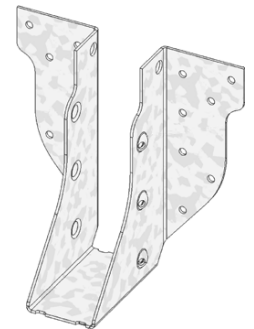

HUS

- 1) Loads listed are based on hanger attachment to a RIGIDLAM® LVL header. Some loads may be increased for duration of load adjustments. Refer to USP's Full Line Catalog for details.
- 2) Uplift loads have been increased 33% or 60% for wind and seismic loading; no further increase shall be permitted.
- 3) Top Mount Hangers require a minimum 3" header thickness for THO series hangers; 3-1/2" minimum header thickness for all other stock numbers.
- 4) 10d x 1-1/2" nails are 9 gauge (0.148" diameter) by 1-1/2" long.
Minimum nail penetration shall be 1-1/2" for 10d nails and 1-5/8" for 16d nails.
16d sinkers (0.148" diameter) by 3-1/4" long may be substituted for 10d common nails with no load reduction.
- 5) Joist nails need to be toe nailed at a 30° to 45° angle to achieve listed loads for THDH and HUS models.
- 6) For additional sizes, stock numbers, and modifications not shown, refer to USP's Full Line Catalog.

Joist Height	USP Stock No. ⁶	Top Mount Hangers ³					Face Mount Hangers								
		Fastener Schedule ⁴		Uplift ²		Down Load ¹	USP Stock No. ⁶	Fastener Schedule ⁴		Uplift ²		Down Load ¹			
		Header	Joist	133%	160%			Header	Joist	133%	160%	100%	115%	125%	
3 Ply 1-3/4" RIGIDLAM® LVL														Header Width = 5-1/4"	
9-1/2	PHXU5295	(8) 16d	(6) 10d	1035	1240	6650	THD610	(38) 16d	(20) 10d	3335	3410	5585	6425	6985	
	HLBH5295	(15) NA16D-RS	(6) 16d	1550	1605	10620	THDH610 ⁵	(46) 16d	(16) 16d	4565	4565	8640	9855	9855	
11-7/8	PHXU52118	(8) 16d	(6) 10d	1035	1240	6650	THD610	(38) 16d	(20) 10d	3335	3410	5585	6425	6985	
	HLBH52118	(15) NA16D-RS	(6) 16d	1550	1605	10620	THDH612 ⁵	(56) 16d	(20) 16d	5180	5180	9935	9935	9935	
14	PHXU5214	(8) 16d	(6) 10d	1035	1240	6650	THD610	(38) 16d	(20) 10d	3335	3410	5585	6425	6985	
	HLBH5214	(15) NA16D-RS	(6) 16d	1550	1605	10620	THDH614 ⁵	(66) 16d	(22) 16d	5795	5795	11645	11645	11645	
16	PHXU5216	(8) 16d	(6) 10d	1035	1240	6650	THD612	(48) 16d	(20) 10d	3335	4000	7055	8115	8415	
	HLBH5216	(15) NA16D-RS	(6) 16d	1550	1605	10620	THDH614 ⁵	(66) 16d	(22) 16d	5795	5795	11645	11645	11645	
18	PHXU5218	(8) 16d	(6) 10d	1035	1240	6650	THD612	(48) 16d	(20) 10d	3335	4000	7055	8115	8415	
	HLBH5218	(15) NA16D-RS	(6) 16d	1550	1605	10620	THDH614 ⁵	(66) 16d	(22) 16d	5795	5795	11645	11645	11645	
4 Ply 1-3/4" RIGIDLAM® LVL														Header Width = 7"	
9-1/2	PHXU7195	(8) 16d	(6) 10d	1035	1240	6650	THD7210	(38) 16d	(20) 16d	3335	3410	5585	6425	6985	
	HLBH7195	(15) NA16D-RS	(6) 16d	1550	1605	10620	THDH7210 ⁵	(46) 16d	(12) 16d	3490	3490	8170	8260	8260	
11-7/8	PHXU71118	(8) 16d	(6) 10d	1035	1240	6650	THD7210	(38) 16d	(20) 16d	3335	3410	5585	6425	6985	
	HLBH71118	(15) NA16D-RS	(6) 16d	1550	1605	10620	THDH7212 ⁵	(56) 16d	(14) 16d	4935	5925	9875	11360	11840	
14	PHXU7114	(8) 16d	(6) 10d	1035	1240	6650	THD7210	(38) 16d	(20) 16d	3335	3410	5585	6425	6985	
	HLBH7114	(15) NA16D-RS	(6) 16d	1550	1605	10620	THDH7214 ⁵	(66) 16d	(16) 16d	5645	6770	11580	11840	11840	
16	PHXU7116	(8) 16d	(6) 10d	1035	1240	6650	HD7120	(16) 16d	(6) 10d	945	1130	2240	2575	2800	
	HLBH7116	(15) NA16D-RS	(6) 16d	1550	1605	10620	THDH7214 ⁵	(66) 16d	(16) 16d	5645	6770	11580	11840	11840	
18	PHXU7118	(8) 16d	(6) 10d	1035	1240	6650	HD7140	(20) 16d	(8) 10d	1260	1510	2800	3220	3500	
	HLBH7118	(15) NA16D-RS	(6) 16d	1550	1605	10620	THDH7214 ⁵	(66) 16d	(16) 16d	5645	6770	11580	11840	11840	

See footnotes on page 8.

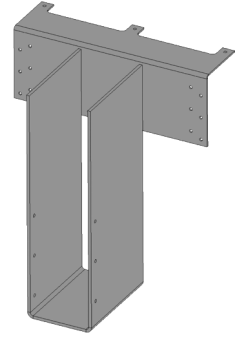

HLBH

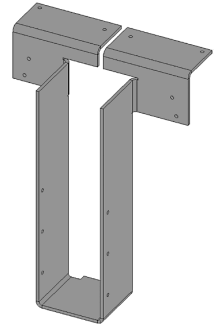

PHXU

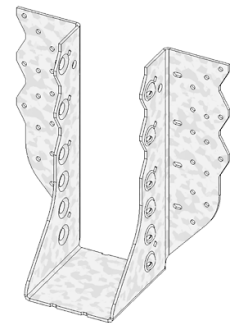

THDH

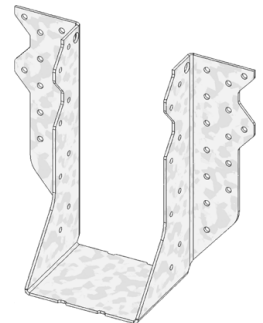

THD

10 VARIABLE PITCH CONNECTORS

The *TMP* and *TMPH* are designed to make rafter-to-plate connections and eliminate time-consuming bird's-mouth notching or bevel plate installation. The *TMP* automatically adjusts to pitches from 1/12 to 6/12 and the *TMPH* from 6/12 to 14/12.

Installation:

- Use all specified fasteners.
- Position connector on top plate. Fasten connector to outside of top plate with specified nails. Insert rafter into rafter pocket. Adjust rafter and pocket to correct pitch. Fasten rafter to connector with specified nails. Installing the *TMP* require driving specified nails through the opposing slots in the pocket. *TMPH* installation involves sliding the fulcrum until it supports the pocket at the desired pitch and nailing down through the fulcrum base into the top plate to lock the fulcrum into position.

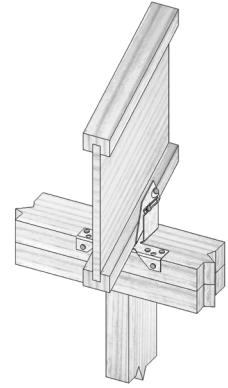
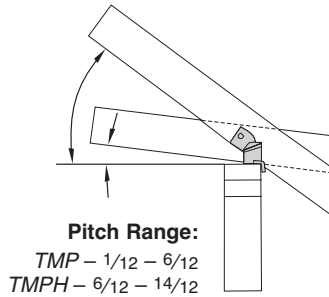

Typical *TMP* installation

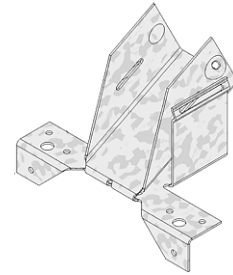

TMP

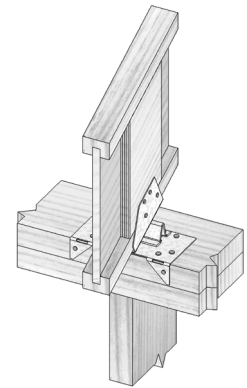

Typical *TMPH* installation

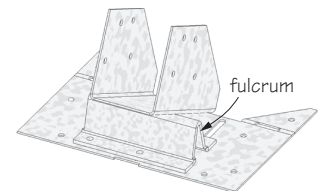

TMPH

Variable Pitch Connectors								
USP Stock No. ^{1,5}	Fastener Schedule ⁴		DF-L/SP			S-P-F		
	Header	Joist	Down ²	Uplift ³		Down ²	Uplift ³	
			100%	133%	160%	100%	160%	133%
RFPI® 20 Joist Width = 1-3/4"								
TMP175	(6) 10d	(4) 10d x 1-1/2	1150	220	220	1150	220	220
TMPH175	(10) 10d	(8) 10d x 1-1/2	1945	200	200	1945	200	200
RFPI® 400 Joist Width = 2-1/16"								
TMP21	(6) 10d	(4) 10d x 1-1/2	1290	220	220	1290	220	220
TMPH21	(10) 10d	(8) 10d x 1-1/2	1945	200	200	1945	200	200
RFPI® 40 Joist Width = 2-5/16"								
TMP23	(6) 10d	(4) 10d x 1-1/2	1970	220	220	1970	220	220
TMPH23	(10) 10d	(8) 10d x 1-1/2	1945	200	200	1945	200	200
RFPI® 50 Joist Width = 1-3/4"								
TMP175	(6) 10d	(4) 10d x 1-1/2	1150	220	220	1150	220	220
TMPH175	(10) 10d	(8) 10d x 1-1/2	1945	200	200	1945	200	200
RFPI® 70 Joist Width = 2-5/16"								
TMP23	(6) 10d	(4) 10d x 1-1/2	1970	220	220	1970	220	220
TMPH23	(10) 10d	(8) 10d x 1-1/2	1945	200	200	1945	200	200
RFPI® 90 Joist Width = 3-1/2"								
TMP4	(6) 10d	(4) 10d x 1-1/2	1970	220	220	1970	220	220
TMPH4	(10) 10d	(8) 10d x 1-1/2	1945	200	200	1945	200	200

- 1) Shaded hangers require web stiffeners at joist ends. Web stiffeners may be required for non-shaded hangers by Roseburg Forest Products.
- 2) Loads listed are based on hanger attachment to a DF-L, SP, or S-P-F species solid sawn or RIGIDLAM® LVL header. Loads are governed by test results; no further increase shall be permitted.
- 3) Uplift loads have been increased 33% or 60% for wind and seismic loading; no further increase shall be permitted.
- 4) 10d x 1-1/2" nails are 9 gauge (0.148" diameter) by 1-1/2" long. Minimum nail penetration shall be 1-1/2" for 10d nails.
- 5) For additional sizes, stock numbers, and modifications not shown, refer to USP's Full Line Catalog.

WS Series Wood Screw Applications - Joining 2, 3, or 4 Ply RIGIDLAM® LVL Members

Installation:

- Screws are self-drilling.
- Install using a low speed clutch drill with 3/8" hex head driver.
The washer head should be flat to the surface and the serrations will oppose turning and release the clutch. Do not over-tighten the screws.
- For 2 ply members, wood screws shall be installed with the screw heads in the loaded ply.
- For 3 or 4 ply members, wood screws shall be installed in both outer plies.
- Designer shall specify all wood screw locations.
- Increase edge and end distances if wood splitting occurs.
- Stagger all screws installed into the opposite face.
- A minimum of 2 rows of screws shall be used for all members 5 1/2" and deeper.

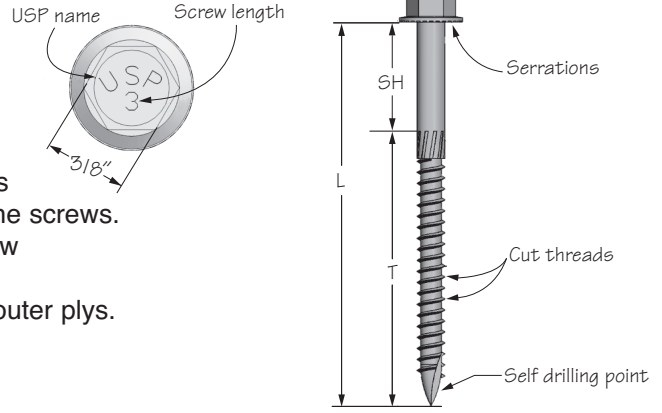

Recommended Row Guidelines
A minimum of 2 rows of screws shall be used for all members 5 1/2" and deeper

Other stagger patterns as approved by Engineer are acceptable

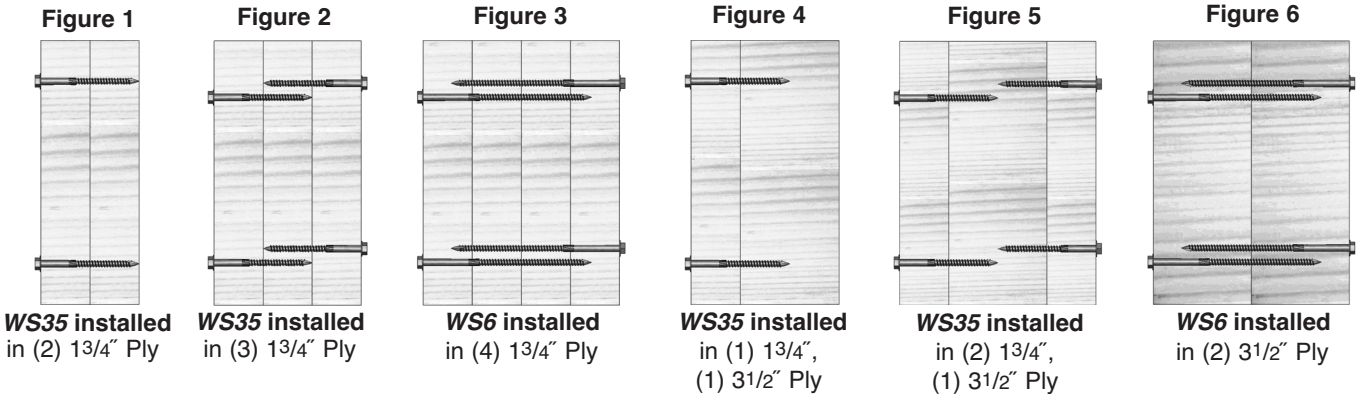
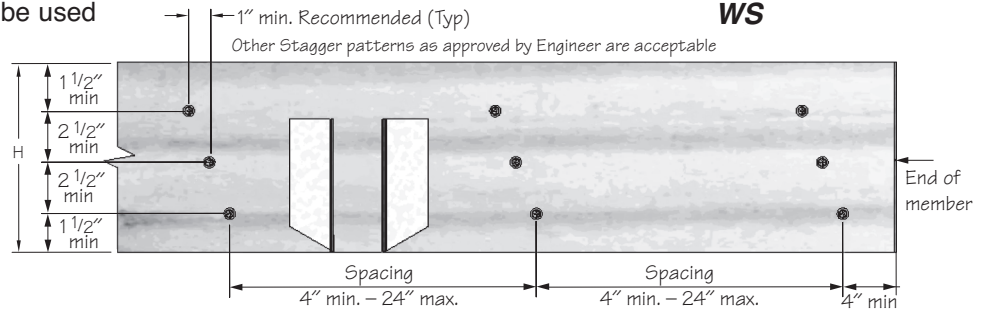

USP Stock No.	Description	Dimensions			Multiple Members Installation Figure 2,3,6	Maximum Allowable Uniform Loads that can be applied to either outside member (Lbs. Per Lineal Ft.) ^{1,4,5,7,8}					
		L	SH	T		Douglas Fir-Larch (G = 0.50)					
						Wood Screw Spacing					
						12" O.C.		18" O.C.		24" O.C.	
2 Rows	3 Rows	2 Rows	3 Rows	2 Rows	3 Rows						
WS35	1/4" x 3-1/2"	3-1/2"	1"	2-1/2"	1	1000	1500	665	1000	500	750
					2	750	1125	500	750	375	565
					4	750	1125	500	750	375	565
					5	665	1000	445	665	335	500
WS6	1/4" x 6"	6"	1-3/4"	4-1/4"	3	665	1000	445	665	335	500
					6	1000	1500	665	1000	500	750

1) Based on Zscrew = 250 pounds in Douglas Fir-Larch with a side member thickness of not less than 1-3/4".
 2) Load values depicted assume all uniform load is applied to the most narrow outside ply only.
 3) Load values neglect any contribution of screws installed to opposite side, even if they extend significantly into the loaded ply.
 4) Loads are for normal (100%) duration of load, and may be increased in accordance with the code.
 5) Uniform loads in table represent the capacity of the fasteners. The capacity of the LVL beam may be less and should be checked by a qualified designer or with the manufacturer's literature.
 6) For Figures 2, 3, 5, and 6: Stagger the screws on opposite face by half minimum spacing requirements.
 7) A qualified designer shall ensure the adequacy of a 7" wide beam to resist the applied load on one edge, otherwise, the loads shall be uniformly distributed across the width or applied equally on both sides.
 8) Allowable loads are based on the 1997 NDS®.



Comprehensive Web Site

- Contains all USP literature in a printable .pdf format
- **CAD Menu Program** and **Drawing Library** downloads
- **Quick and Easy** literature ordering
- Register on-line at **Web Site Watch Registration** and automatically receive product updates through your e-mail

CAD Menu Program

- Install a new **USP Drop Down Menu** in your AutoCAD menu bar (AutoCAD r14, AutoCAD 2000, 2000i, 2002, 2004, 2005)
 - Import scalable USP product drawings directly into your details or section drawings
- Available in 3-view format; top, front, and side where applicable**

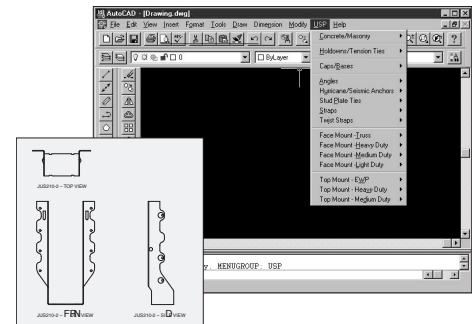

CAD Library

- CAD Library contains over 350 illustrations in .DXF and .DWG formats
- Find drawings quickly by USP Stock No. or Reference No.
- High Wind Illustrations are also available

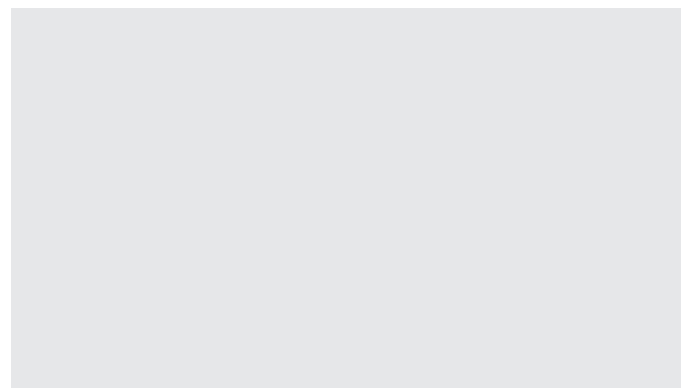
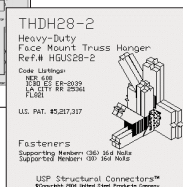
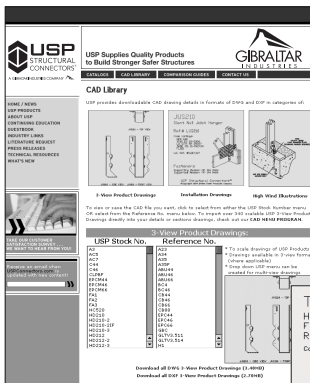

Your Local Dealer / Distributor